

360° Non-Contacting Rotary Dual Output Hall Effect Sensor

9360 Series

The BEI Duncan 9360 Series rotary sensor is a non-contacting Hall effect device with 360° of rotation and dual outputs. This rugged design is ideally suited for infinite rotation applications where reliability and durability are a priority. The sensor provides absolute position at power on and offers two completely redundant outputs. The packaging is similar to other BEI devices and meets the severe durability requirements that are typical in off-highway and agriculture requirements. The new sensor incorporates a rotating Neodymium disk magnet that enables the sensing element to remain stationary, improving both accuracy and reliability. This combination of magnet, sensor and sealed packaging offers excellent temperature stability and corrosion resistance. The sensor can be configured for Analog (voltage) outputs or with a PWM output. These programmability features are configured at the factory and allow for greater flexibility in creating custom limited electrical angle outputs (i.e. 0-20 degrees for full scale) with short turnaround times.

Fully sealed, (meeting and/or exceeding IP66/IP67 standards) the 9360 is impervious to contamination and moisture. An integrally molded 6-pin connector makes a sealed connection with industry standard Packard Electric connector.

9360 Series Features

Rotating magnet / fixed sensor configuration

Provides improved accuracy and reliability

Fully programmable

The standard sensor provides 0-359.9° electrical degrees. Multiple outputs with limited electrical angles up to 359.9° temperature compensation are also available

Compression molded Neodymium magnets

Provide excellent temperature stability and corrosion resistance

Ratiometric analog output or PWM output

Factory programming through connector

Allows for quick turn-around on custom electrical angles

Sealed construction

IP66 / IP67, 6-pin I/O interface to Packard Electric Metri-Pack Pull-to-Seat 150.2 Series P/N 12162261 or P/N 12162260 connector

Extended temperature range

-40° to +85°C standard, -40° to +125°C available optionally

Extended operating life

Maximum rotational speed limited to 300 RPM



Ordering Information

9360	-	XXX	-	y
		*Standard Active Electrical Angles	Spring Return	
		015 = 15 degrees	1 = Clockwise Rotation	
		030 = 30 degrees	2 = Counter Clockwise Rotation	
		045 = 45 degrees	3 = No Spring	
		060 = 60 degrees		
		075 = 75 degrees		
		080 = 80 degrees		
		105 = 105 degrees		
		120 = 120 degrees		
		135 = 135 degrees		
		150 = 150 degrees		
		165 = 165 degrees		
		180 = 180 degrees		

XXX		y			Active Electrical Angle
	1	2	3		
015	X	X	X		15 degrees
030	X	X	X		30 degrees
045	X	X	X		45 degrees
060	X	X	X		60 degrees
075	X	X	X		75 degrees
090	X	X	X		90 degrees
105	X	X	X		105 degrees
120	X	X	X		120 degrees
135	X	X	X		135 degrees
150	X	X	X		150 degrees
165	X	X	X		165 degrees
180	X	X	X		180 degrees
195			X		195 degrees
210			X		210 degrees
225			X		225 degrees
240			X		240 degrees
255			X		255 degrees
270			X		270 degrees
285			X		285 degrees
300			X		300 degrees
315			X		315 degrees
330			X		330 degrees
345			X		345 degrees
360			X		360 degrees

*Other angles available, consult factory.

Consult factory for options including:

- Non-standard output slope
- Clipped outputs
- Non-standard Active Electrical Angles
- PWM output (pulse width modulation)
- Special marking
- Non-standard linearity

Custom solutions can also be addressed, including:

- CAN Bus output
- Single output 3-pin
- Wire harness

Valid part numbers

XXX	y			Active Electrical Angle
	1	2	3	
015	X	X	X	15 degrees
030	X	X	X	30 degrees
045	X	X	X	45 degrees
060	X	X	X	60 degrees
075	X	X	X	75 degrees
090	X	X	X	90 degrees
105	X	X	X	105 degrees
120	X	X	X	120 degrees
135	X	X	X	135 degrees
150	X	X	X	150 degrees
165	X	X	X	165 degrees
180	X	X	X	180 degrees
195			X	195 degrees
210			X	210 degrees
225			X	225 degrees
240			X	240 degrees
255			X	255 degrees
270			X	270 degrees
285			X	285 degrees
300			X	300 degrees
315			X	315 degrees
330			X	330 degrees
345			X	345 degrees
360			X	360 degrees

X = available



170 Technology Drive West
Irvine, CA 92618-2401
(949) 341-9530 Fax: (949) 453-2700
email: sales@beiduncan.com
www.beiduncan.com

ISO9001

Certified

360° Non-Contacting Rotary Dual Output Hall Effect Sensor

9360 Series

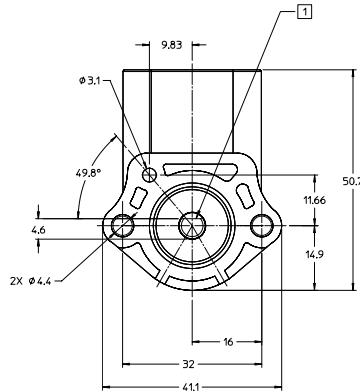
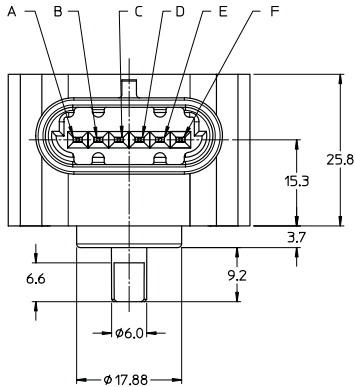

Note: All dimensions are shown in millimeters
 Note \square : Shaft is positioned at 50% voltage output

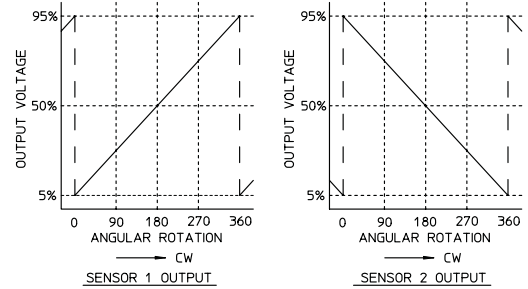

CONNECTOR PIN OUTPUT		
	SENSOR 1	SENSOR 2
V _s (INPUT)	F	B
GROUND	E	A
OUTPUT	C	D

Mechanical Specifications

Mechanical travel	0° to +360° with no stops, allowing for infinite rotations
Frequency response	1,000Hz minimum
Rotational torque	0.025 – 0.110 N-m
Weight	35 grams (approx.)

Electrical Specifications

Mechanical input range	0° to +360° (other, custom limited angle ranges available)
Input voltage	5.0 V \pm 0.25V DC
Input current	18mA maximum per output 36mA maximum total (both channels)
Sensor	0.25V – 4.75V for Analog at 5.0V input 5% – 95% duty cycle for PWM (Different outputs and mechanical range(s) available as a custom option)
Accuracy	\pm 0.6% of full scale at room temperature \pm 0.9% of full scale over operating temperature range
Resolution	Analog (continuous)

Environmental Specifications

Electromagnetic compatibility	100V/meter, 14kHz – 1GHz range
Vibration	10G peak, 20 – 2,000 Hz
Shock	50Gs, half sine pulse, 5 m sec duration
Side load	1kg for 1 million cycles
Operating temperature range	-40°C to +85°C (wider operating temperature -40° to +125 C° available)
Storage temperature range	-55°C to +105°C

© Copyright 2007 BEI Duncan Electronics. Specifications subject to change without notice.



170 Technology Drive West
 Irvine, CA 92618-2401
 (949) 341-9530 Fax: (949) 453-2700
 email: sales@beiduncan.com
 www.beiduncan.com

ISO9001

Certified

Ordering Inforamtion

9360 -

XXX	
*Standard Active Electrical Angles	
015 = 15 degrees	195 = 195 degrees
030 = 30 degrees	210 = 210 degrees
045 = 45 degrees	225 = 225 degrees
060 = 60 degrees	240 = 240 degrees
075 = 75 degrees	255 = 255 degrees
090 = 90 degrees	270 = 270 degrees
105 = 105 degrees	285 = 285 degrees
120 = 120 degrees	300 = 300 degrees
135 = 135 degrees	315 = 315 degrees
150 = 150 degrees	330 = 330 degrees
165 = 165 degrees	345 = 345 degrees
180 = 180 degrees	360 = 360 degrees
*Other angles available, consult factory.	

y	
Spring Return	
1 = Clockwise Rotation	
2 = Counter Clockwise Rotation	
3 = No Spring	

Valid part numbers

XXX	y			Active Electrical Angle
	1	2	3	
015	X	X	X	15 degrees
030	X	X	X	30 degrees
045	X	X	X	45 degrees
060	X	X	X	60 degrees
075	X	X	X	75 degrees
090	X	X	X	90 degrees
105	X	X	X	105 degrees
120	X	X	X	120 degrees
135	X	X	X	135 degrees
150	X	X	X	150 degrees
165	X	X	X	165 degrees
180			X	180 degrees
195			X	195 degrees
210			X	210 degrees
225			X	225 degrees
240			X	240 degrees
255			X	255 degrees
270			X	270 degrees
285			X	285 degrees
300			X	300 degrees
315			X	315 degrees
330			X	330 degrees
345			X	345 degrees
360			X	360 degrees

X = available

Consult factory for options including:

- Non-standard output slope
- Clipped outputs
- Non-standard Active Electrical Angles
- PWM output (pulse width modulation)
- Special marking
- Non -standard linearity

Custom solutions can also be addressed, including:

- CAN Bus output
- Single output 3-pin
- Wire harness